

# 19" Wall Mounting Cabinet

## 10U x D450

Item no.: LVR240005



### PRODUCT OVERVIEW

Wall-mounted 600mm wide rack cabinet designed for the installation of both cabling and equipment. Suitable for multiple applications including local area networking (LAN) cabling and hardware, and the housing of surveillance and audio visual equipment.

### SPECIFICATIONS

<b>Type</b>	Wall mounted rack cabinet
<b>Modular spacing</b>	19"
<b>Rack capacity</b>	10U
<b>Color</b>	Beige
<b>Material</b>	Steel
<b>Front door</b>	Plate
<b>Front door key lock</b>	Yes
<b>Removable front door</b>	Yes
<b>Removable side panels</b>	Yes
<b>Mounting profile</b>	Front and rear
<b>Rail thickness</b>	1.5 mm
<b>Ventilation</b>	Passive, space for 2 fans

<b>Industry standard compliance</b>	Comply with ANSI/EIA RS-310-D, DIN41491; PART1, IEC297-2, DIN41494; PART7, GB/T3047.2-92 standard. Compatible with metric, ETSI and 19" international standard
<b>Width</b>	600 mm
<b>Height</b>	553 mm
<b>Depth</b>	450 mm
<b>Maximum weight capacity</b>	60 kg
<b>Package</b>	Flatpack



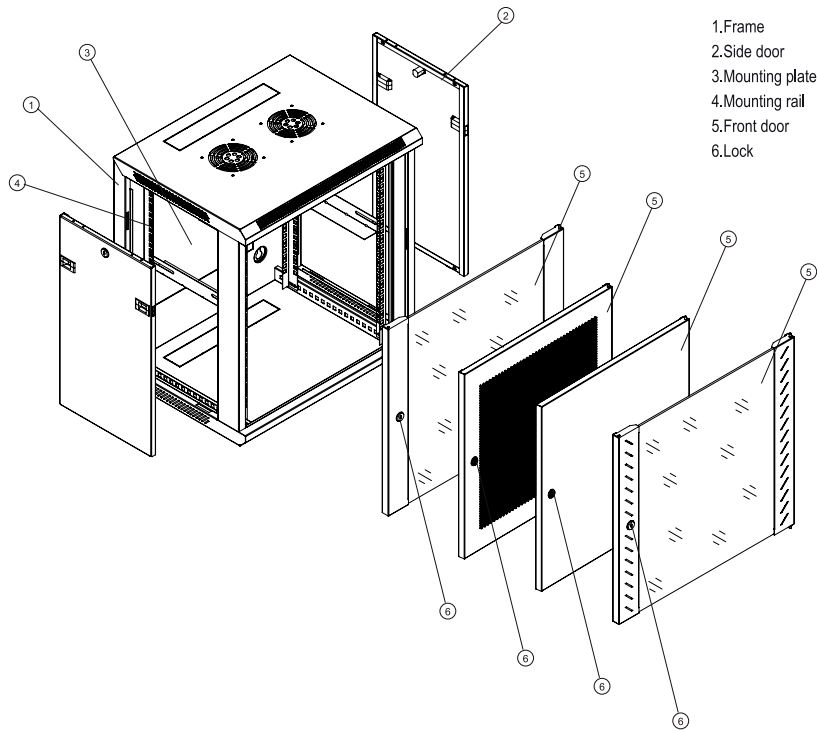

- 1. Frame
- 2. Side door
- 3. Mounting plate
- 4. Mounting rail
- 5. Front door
- 6. Lock

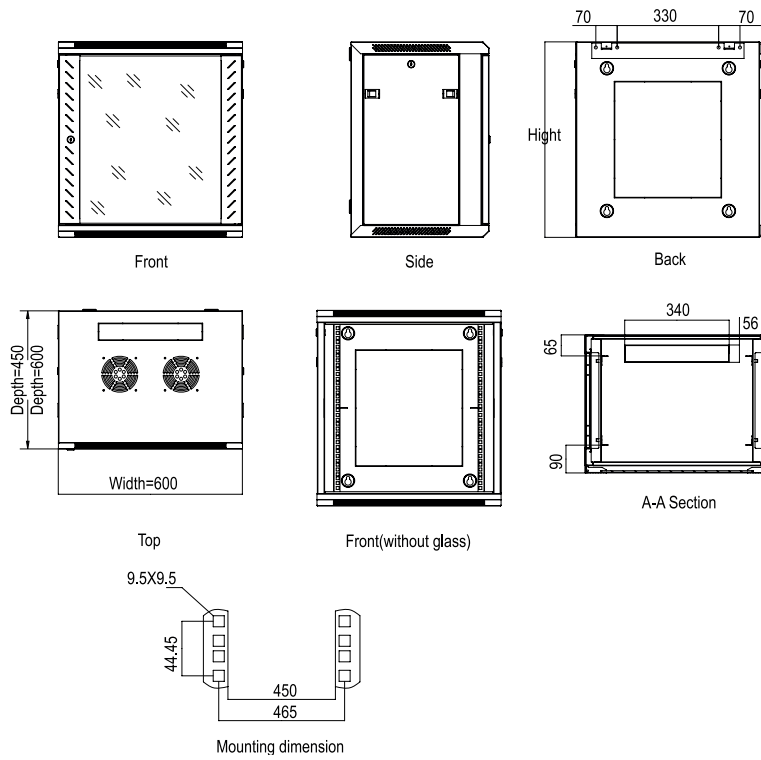

## 19'' Wall Mounting Cabinet 10U x D450