

# User Manual

## Optical Headend

Ref. 4005 & 4006 & 4007

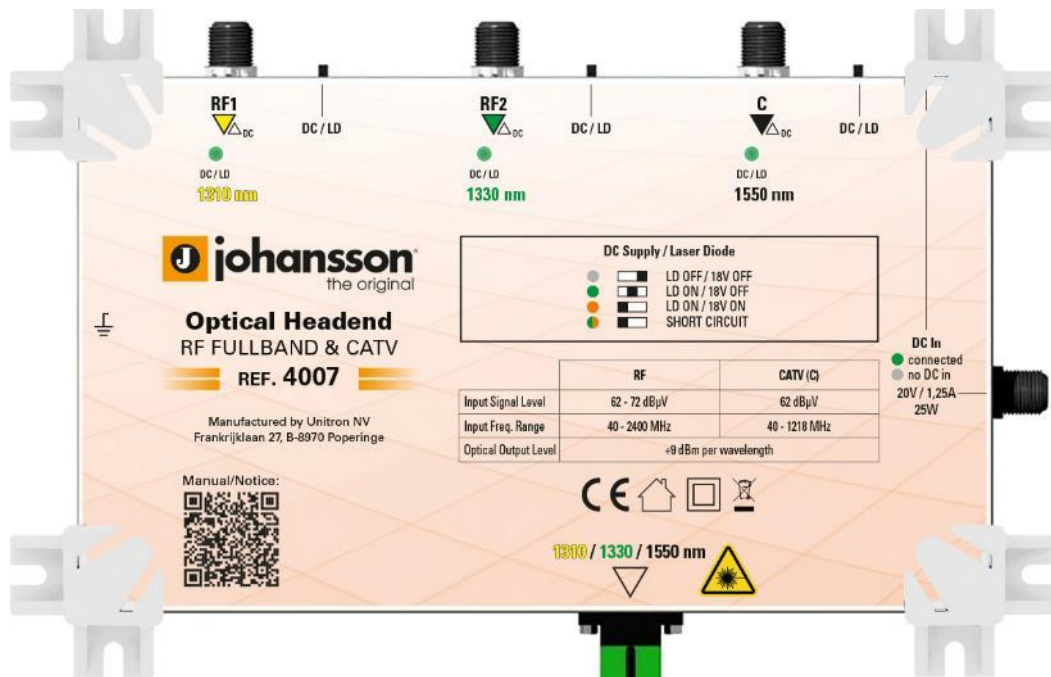

## CONTENTS

<b>1. INTRODUCTION .....</b>	<b>3</b>
Product description .....	3
Package contents .....	3
<b>2. CONFIGURATION OF THE MODULE.....</b>	<b>4</b>
<b>3. INSTALLATION OF THE HARDWARE .....</b>	<b>5</b>
<b>4. TECHNICAL SPECIFICATIONS .....</b>	<b>7</b>
<b>5. SAFETY INSTRUCTIONS .....</b>	<b>8</b>
<b>6. CONDITIONS OF WARRANTY .....</b>	<b>9</b>

No part of this manual may be copied, reproduced, transmitted, transcribed or translated into any language without permission.

Unitron reserves the right to change the specifications of the hardware and software described in these manuals at any time.

Unitron cannot be held liable for any damages resulting from the use of this product. Specifications are subject to change without notice. 2/23

© Unitron NV - Frankrijklaan 27 - B-8970 Poperinge - Belgium

T +32 57 33 33 63 F +32 57 33 45 24

sales@unitrongroup.com

www.unitrongroup.com

# 1. INTRODUCTION

## Product description

The REF.4005/4006/4007 are similar to REF.4002 and 4003 without integrated AGC and ASC. They also receive RF fullband signals (40-2400 MHz). The Optical Transmitters are suited for many types of optical systems: up to 64 splits, up to 128 splits!

### **REF 4005: OPTICAL HEADEND TRANSMITTER RF FULLBAND 1 WAVELENGTH**

- 1 Fullband input
- frequency range: Full band: 40 – 2400 MHz
- 1 Optical output (wavelength 1550nm)

### **REF 4006: OPTICAL HEADEND TRANSMITTER RF FULLBAND 2 WAVELENGTHS**

- 2 Full band inputs
- frequency range: Full band: 40 – 2400 MHz
- 1 Optical output (wavelengths 1310 – 1330nm)

### **REF 4007: OPTICAL HEADEND TRANSMITTER RF FULLBAND & CATV 3 WAVELENGTHS**

- 2 Full band and 1 CATV inputs
- frequency range: Full band: 40 – 2400 MHz / CATV: 40 – 1218 MHz
- 1 Optical output (wavelengths 1310 – 1330 - 1550nm)

## Package contents

- 1x Optical Headend (REF 4005 or REF 4006 or REF 4007)
- **Not included:** 20V / 3A Power Supply (Ref. 2460)

## 2. CONFIGURATION OF THE MODULE

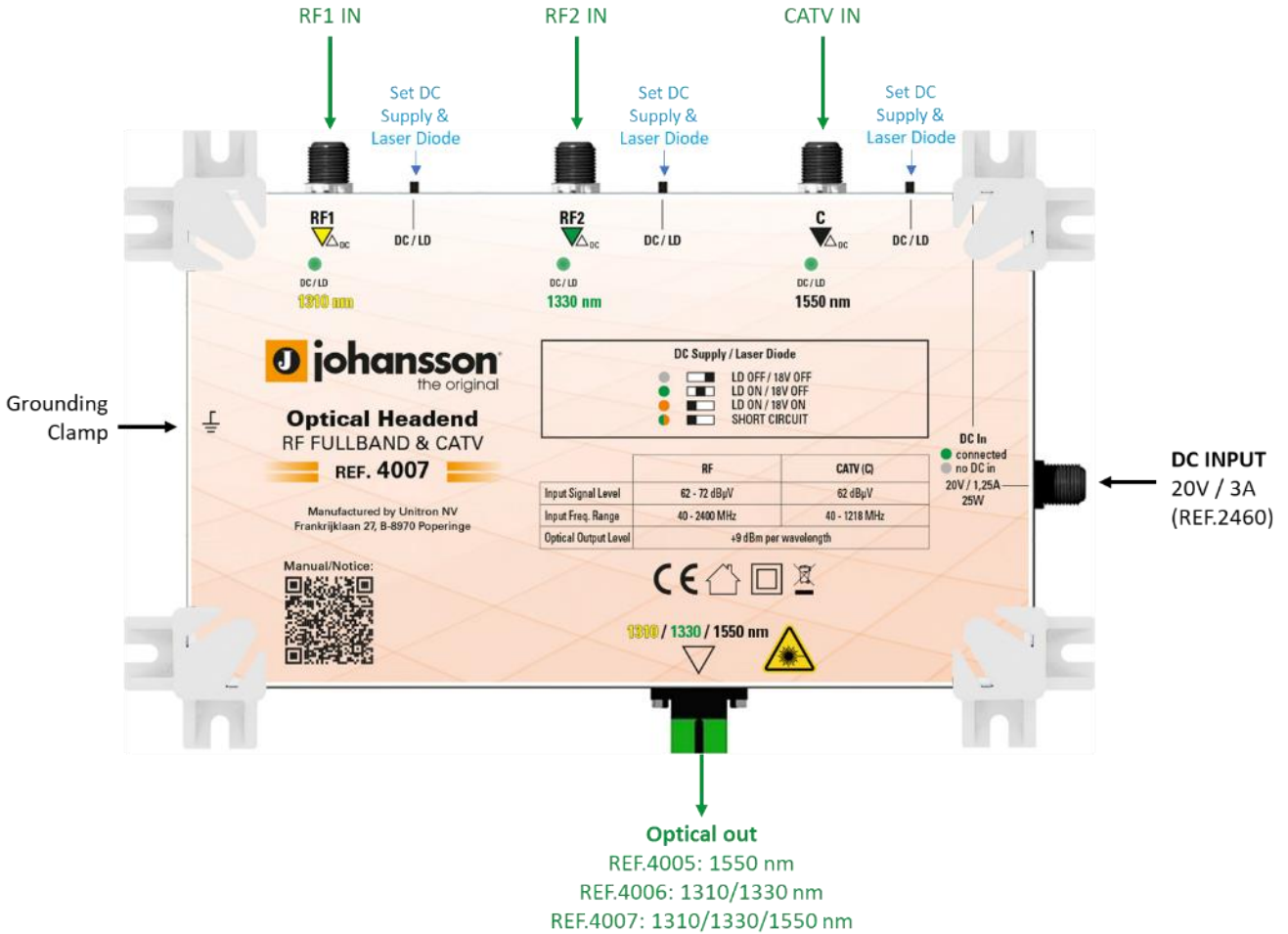

### Set DC Supply and Laser Diode:

With this switch you can set the DC (18V) supply to the RF input and switch off the Laser Diode (LD) in order to measure each optical signal separately. To measure the signal strength of a certain wavelength, you need to switch off both other Laser Diodes. Don't forget to switch all LDs on after measurement.

The LED is **off** if no DC is supplied to the RF input and if no DC is supplied to the Laser Diode. If no DC is supplied to the laser diode, the related signal is not converted into an optical signal. Please make sure to switch on at least the laser diode for proper operation.

The LED is **green** if the Laser diode is switched on and the related output voltage off.

The LED is **orange** if the Laser diode is switched on the related output voltage is supplied to the RF input.

The LED is **green/orange** blinking if DC is supplied to the RF input and the device recognized a short circuit.

### Optical output:

The optical transmitters each have an optical output power of +9 dBm per wavelength.

### 3. INSTALLATION OF THE HARDWARE

#### RTV-SAT distribution over Fiber Optic Network ICT-2: according to RD346/2011 (Spanish ICT-law)

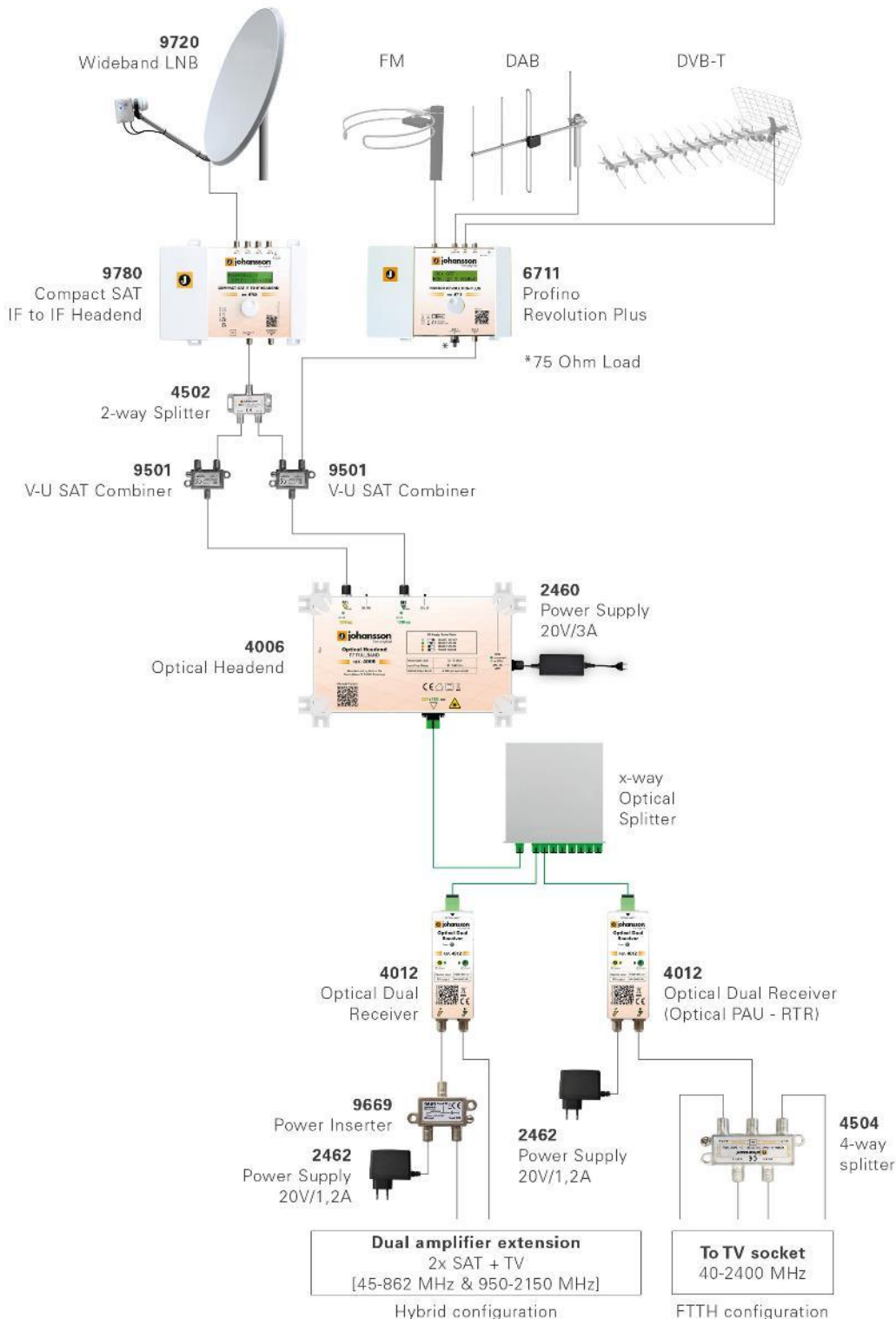

## GPON RF Overlay: RTV-SAT Distribution over Fiber Optic Network

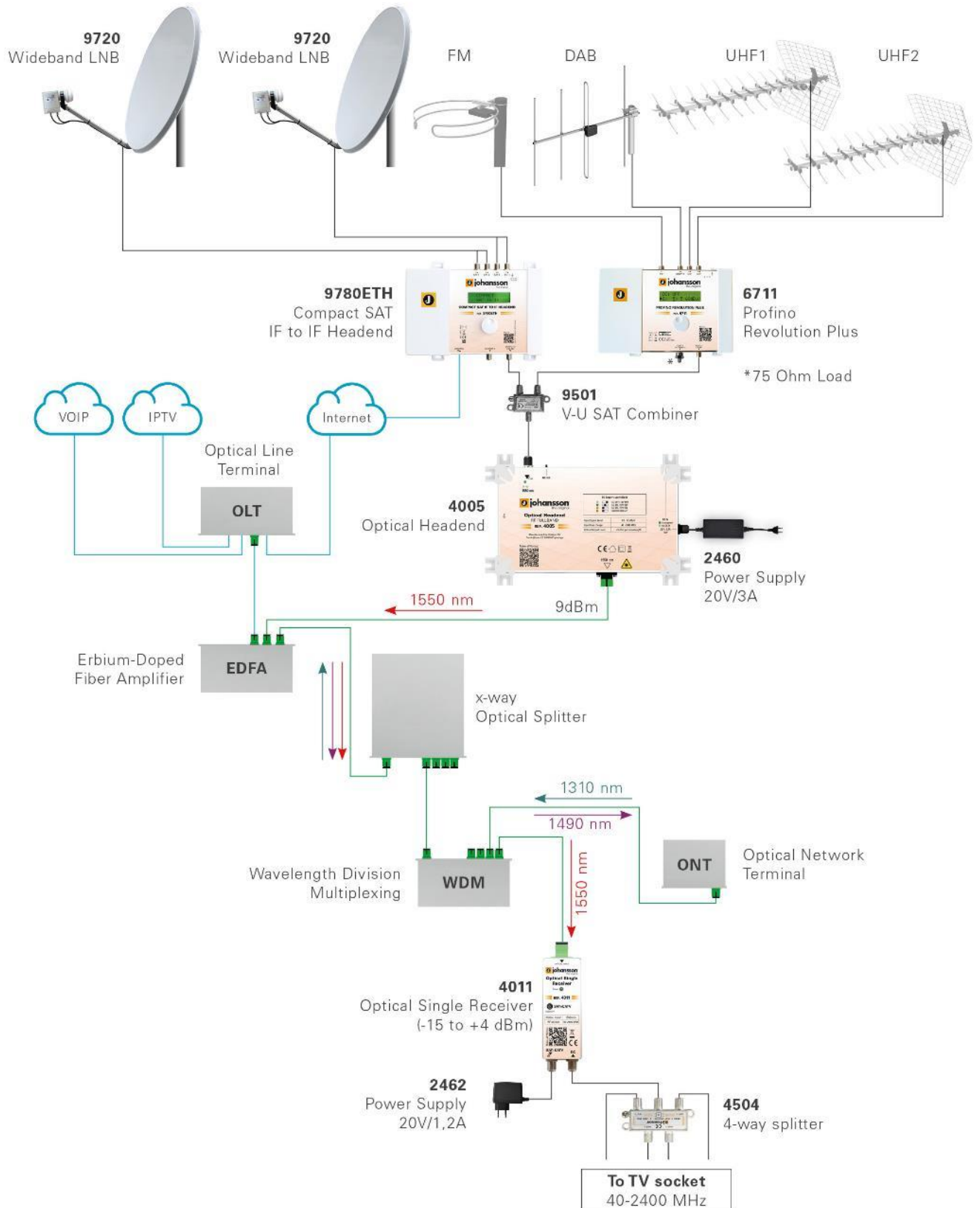

## 4. TECHNICAL SPECIFICATIONS

		REF 4005	REF 4006	REF 4007
RF Inputs (F-connector)	-	1 x Full band	2 x Full band	2 x Full band 1 x CATV
Input frequency RF	MHz	-	40 - 2400	
Input frequency CATV	MHz	40 – 2400	-	40 - 1218
Optical outputs (SC/APC)	-	1		
Optical output wavelengths	nm	1550	1310 – 1330	1310 – 1330 – 1550
Optical output power	dBm	+9 (per wavelength)		
Minimal input level RF	dB $\mu$ V	62 (64QAM) - 67 (16QAM) - 72 (QPSK)		
Minimal input level CATV	dB $\mu$ V	62	-	62
DC supply	-	18V / 400mA		
DC supply CATV	-	-		12V / 200mA
Power consumption	W	10	20	25
DC input (F-type)	-	20 V / 0,5 A	20 V / 1 A	20 V / 1,25 A
Power Supply	-	Use a 20V / 3A Power Supply (Ref. 2460) Not included with product		
Operating temperature range	°C	-10 to +50		
Dimensions	Mm	221 x 141 x 50		
Weight	kg	0.8		

## 5. SAFETY INSTRUCTIONS



**Read these instructions carefully before connecting the unit**



To prevent fire, short circuit or shock hazard:

- Do not expose the unit to rain or moisture.
- Install the unit in a dry location without infiltration or condensation of water.
- Do not expose it to dripping or splashing.
- Do not place objects filled with liquids, such as vases, on the apparatus.
- If any liquid should accidentally fall into the cabinet, disconnect the power plug.



To avoid any risk of overheating:

- Install the unit in a well aery location and keep a minimum distance of 15 cm around the apparatus for sufficient ventilation
- Do not place any items such as newspapers, table-cloths, curtains, on the unit that might cover the ventilation holes.
- Do not place any naked flame sources, such as lighted candles, on the apparatus
- Do not install the product in a dusty place
- Use the apparatus only in moderate climates (not in tropical climates)
- Respect the minimum and maximum temperature specifications



To avoid any risk of electrical shocks:

- Connect apparatus only to socket with protective earth connection.
- The mains plug shall remain readily operable
- Pull out power plug to make the different connections of cables
- To avoid electrical shock, do not open the housing of adapter.



**Maintenance**



Only use a dry soft cloth to clean the cabinet.



Do not use solvent



For repairing and servicing refer to qualified personnel.



**Dispose according your local authority's recycling processes**



## 6. CONDITIONS OF WARRANTY

Unitron N.V. warrants the product as being free from defects in material and workmanship for a period of 24 months starting from the date of production indicated on it. See note below.

If during this period of warranty the product proves defective, under normal use, due to defective materials or workmanship, Unitron N.V, at its sole option, will repair or replace the product. Return the product to your local dealer for reparation.

### **THE WARRANTY IS APPLIED ONLY FOR DEFECTS IN MATERIAL AND WORKMANSHIP AND DOES NOT COVER DAMAGE RESULTING FROM:**

- Misuse or use of the product out of its specifications,
- Installation or use in a manner inconsistent with the technical or safety standards in force in the country where the product is used,
- Use of non-suitable accessories (power supply, adapters...),
- Installation in a defect system,
- External cause beyond the control of Unitron N.V. such as drop, accidents, lightning, water, fire, improper ventilation...

### **THE WARRANTY IS NOT APPLIED IF**

- Production date or serial number on the product is illegible, altered, deleted or removed.
- The product has been opened or repaired by a non-authorized person.

### **NOTE**

Date of production can be found in the product's serial number code. The format will either be "YEAR W WEEK" (e.g., 2017W32 = year 2017 week 32) or "YYWW" (e.g., 1732 = year 2017 week 32).



[www.unitrongroup.com](http://www.unitrongroup.com)

**UNITRON NV**  
**Frankrijklaan 27**  
**B-8970 Poperinge**  
**Belgium**

**T +32 57 33 33 63**

[sales@unitrongroup.com](mailto:sales@unitrongroup.com)

[www.unitrongroup.com](http://www.unitrongroup.com)